

USER MANUAL



Thank you for choosing Better Bathrooms.
Please read this manual before installing your product
and keep for future reference.

better 
bathrooms

Product

BeBa_27706 - Camden Concealed Thermostatic Shower Valve 2 Outlet Chrome

BeBa_27707 - Camden Concealed Thermostatic Shower Valve 2 Outlet Matt Black

BeBa_27708 - Camden Concealed Thermostatic Shower Valve 2 Outlet Brushed Brass

BeBa_27709 - Camden Concealed Thermostatic Shower Valve 1 Outlet - Chrome

BeBa_27710 - Camden Concealed Thermostatic Shower Valve 1 Outlet - Matt Black

BeBa_27711 - Camden Concealed Thermostatic Shower Valve 1 Outlet - Brushed Brass

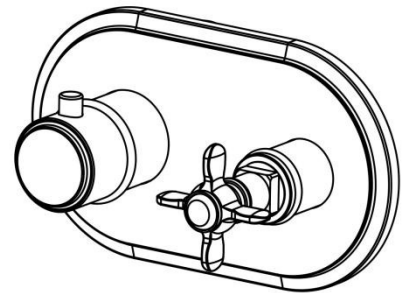
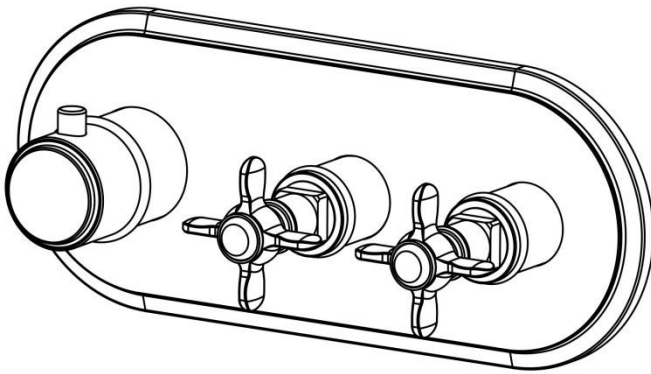

- **Single-person assembly**
- **Tools required**
- **We always recommend using professional tradespeople to install your product**

V1_17/11/2021

Congratulations on your purchase

And welcome to our growing gang of savvy shoppers

We're on a mission to bring you extraordinary bathroom products, for less. From modern to traditional style ceramics, plus the gorgeous fixtures, fittings and furniture to match. So, you can fall in love with your space every single day.

As one of the UK's largest independent bathroom stores, we've received countless awards; including the National Business Awards UK, the Digital Entrepreneur Awards and being placed on The Sunday Times Fast Track 100.

We hope your new product goes above and beyond your expectations. However, should any problems occur, please:

- log in to your account and contact our customer services team via your self-serve portal – betterbathrooms.com/CustomerAccount/Login
- contact us via betterbathrooms.com/content/contact-us

Important information

- Please read these instructions thoroughly and retain for future reference
- Installation must be carried out in compliance with The Water Fittings Regulations and Scottish Water Byelaws.
- The system must be flushed prior to installation
- Minimum and Maximum working pressure for BeBa_27706 / BeBa_27707 / BeBa_27708 : 1 - 5 bar
- Minimum and Maximum working pressure for BeBa_27709 / BeBa_27710 / BeBa_27711 : 0.5 - 5 bar
- Pressures must be equal for optimum performance
- Please do not connect hot and cold water supply lines in reverse. This could result in hot water flowing from cold line and cause scalding.
- The feed-water temperature of water shall not exceed 85° C.
Exceeding 85° may cause scalding, the service life of faucets might be shortened, or the faucet might be damaged.
- After installation, please make sure the faucet is securely mounted and checked for leaks.

Parts / Diagrams

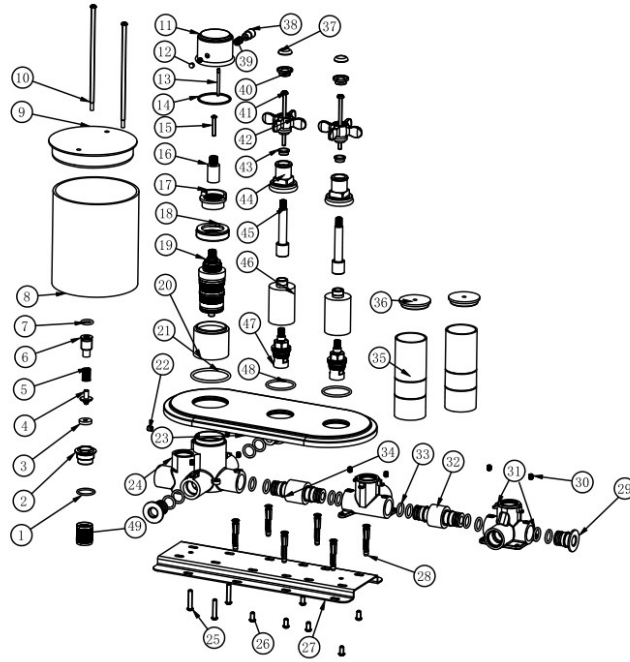

No	Part Description	No	Part Description	No	Part Description
1	O-ring	18	Locknut	35	Plastic template
2	Housing	19	Thermostatic cartridge	36	Cover for plastic template
3	Rubber washer	20	Trim Cover	37	Ceramic cap
4	Rod	21	O-ring	38	Safety button
5	Spring	22	Screw	39	Spring
6	Non-return valve	23	Trim cover Plate	40	Decorative cover
7	O-ring	24	Thermostatic body	41	Screw
8	Plastic template	25	Wall screw	42	Cross handle
9	Cover for plastic template	26	Wall screw	43	Angle limiter
10	Screw	27	SS mounting plate	44	Trim cover
11	Thermostatic handle	28	Plug for wall screw	45	Rod
12	Cap	29	Plug	46	Trim cover
13	Screw	30	Screw	47	Divertor
14	POM ring	31	Divertor body	48	O-ring
15	Screw	32	Connecting pipe short	49	Filter mesh
16	Connector	33	O-ring		
17	Angle limiter	34	Connecting pipe		

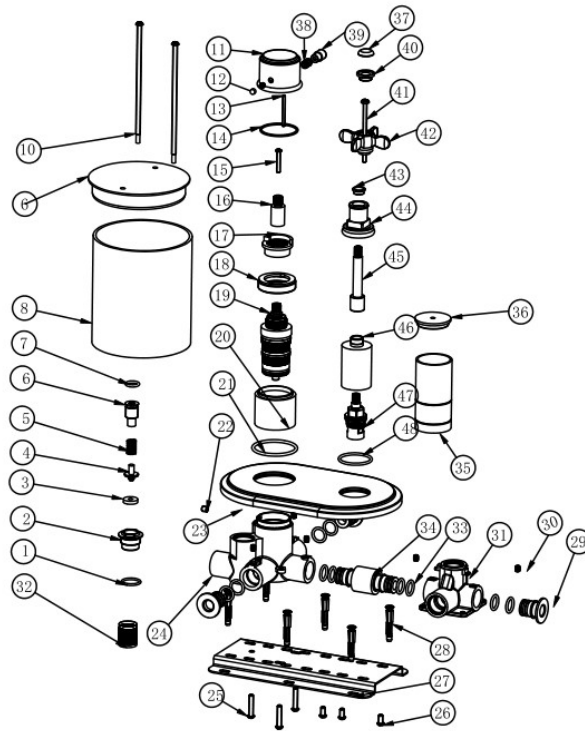

No	Part Description	No	Part Description	No	Part Description
1	O-ring	18	Locknut	35	Plastic template
2	Housing	19	Thermostatic cartridge	36	Cover for plastic template
3	Rubber washer	20	Trim Cover	37	Ceramic cap
4	Rod	21	O-ring	38	Safety button
5	Spring	22	Screw	39	Safety button
6	Non-return valve	23	Trim cover Plate	40	Decorative cover
7	O-ring	24	Thermostatic body	41	Screw
8	Plastic template	25	Wall screw	42	Cross handle
9	Cover for plastic template	26	Wall screw	43	Angle limiter
10	Screw	27	SS mounting plate	44	Trim cover
11	Thermostatic handle	28	Plug for wall screw	45	Rod
12	Cap	29	Plug	46	Trim cover
13	Screw	30	Screw	47	Divertor
14	POM ring	31	Divertor body	48	O-ring
15	Screw	32	Filter mesh		
16	Connector	33	O-ring		
17	Angle limiter	34	Connecting pipe		

Dimensions

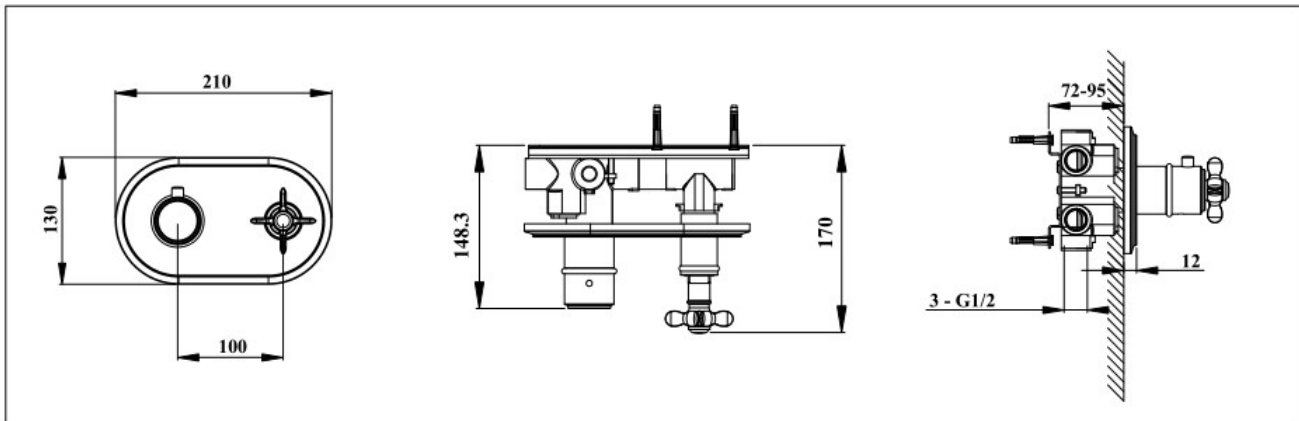
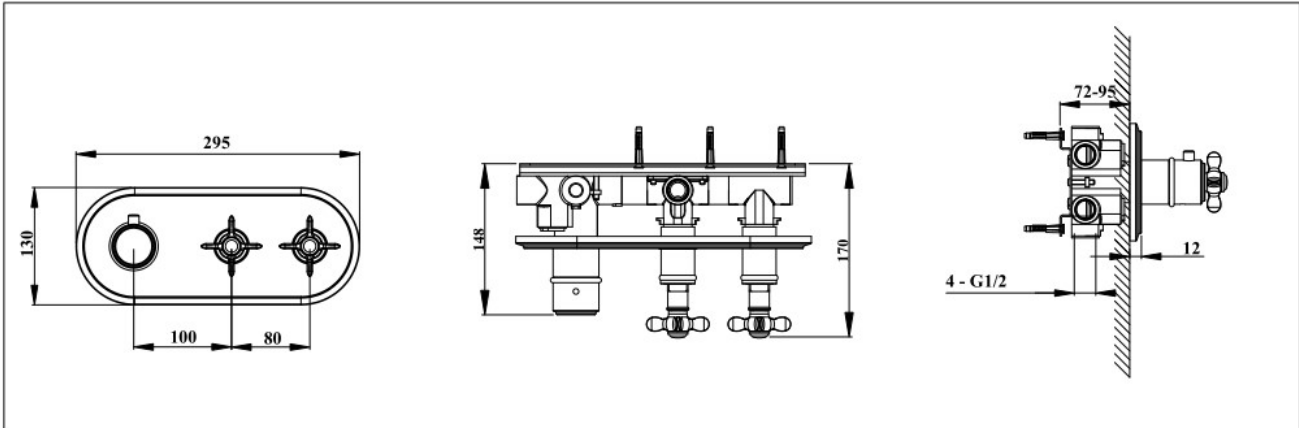

Tools required

- Spanner
- Drill and bit
- Hammer
- PTFE/Teflon tape
- Marker
- Knife or saw
- Measuring tape
- Scredriver
- Thermometer
- Spirit level

Installation

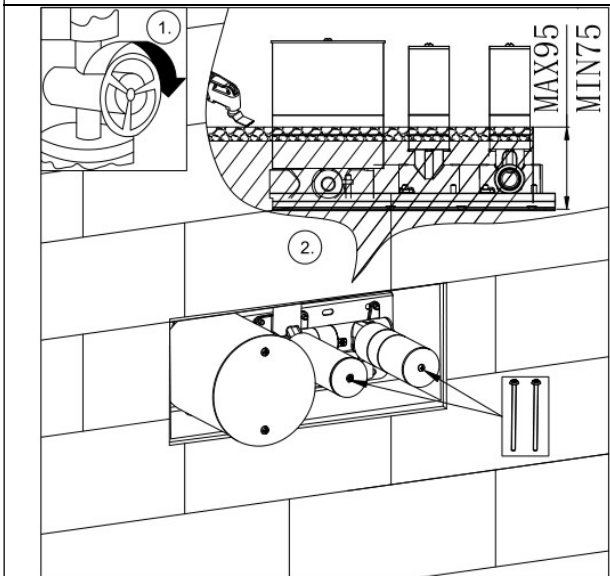
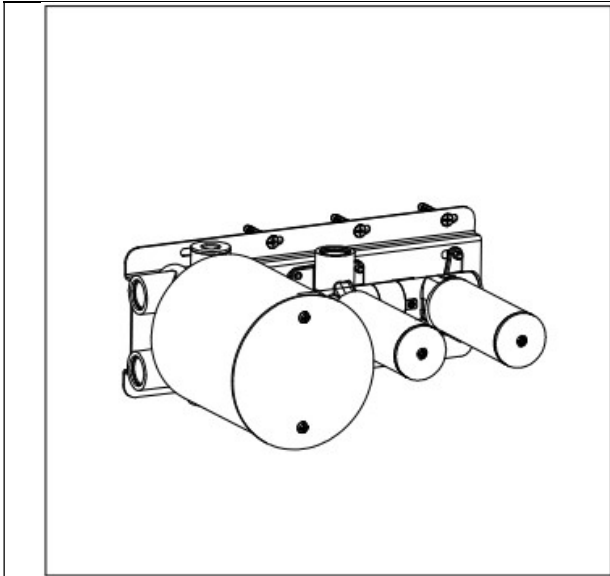

Prior to installation ensure that the hot and cold water supplies are both shut off.

The recess should be made such as to have the mixer protrude out of the surface at the indicated markings (72mm minimum and 95mm maximum).

Use the spirit level to level the unit.

Connect the water supplies and outlets securely.

Keep the screws of diverter plastic templates and assemble to the diverter handles afterwards.

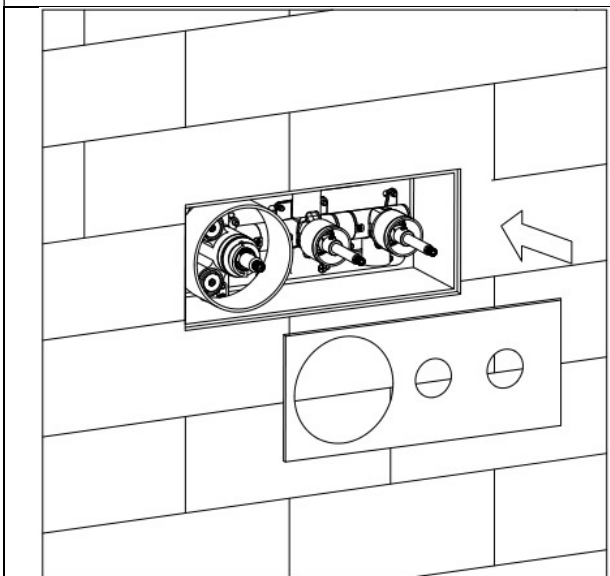

Finish the wall as required.

Ensure tiles are cut as close to the plastic template covering the mixer dome as possible; remove the plastic covers after the tiling is completed

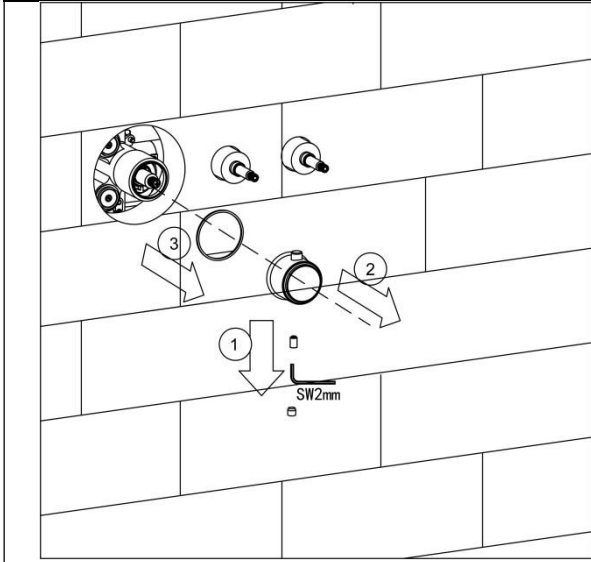

Disassemble the thermostatic handle and POM ring from the mixer.

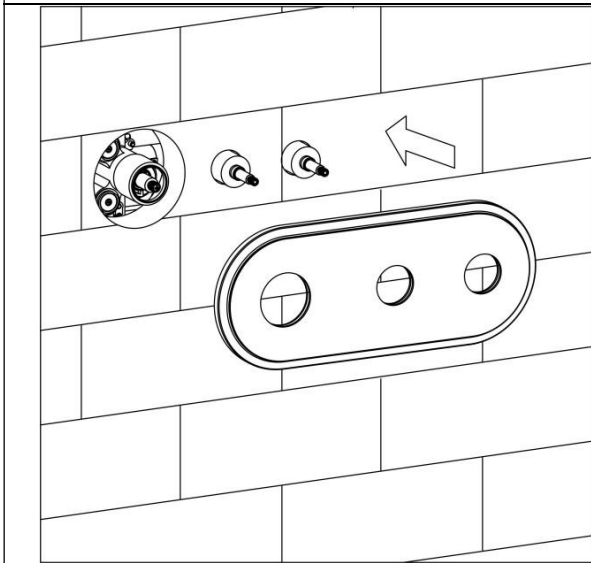

Install the decorative cover plate.

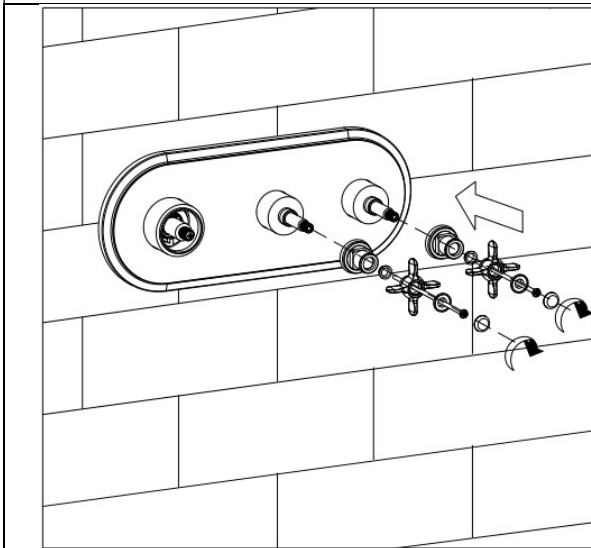

Install the trim covers and diverter handles into position.

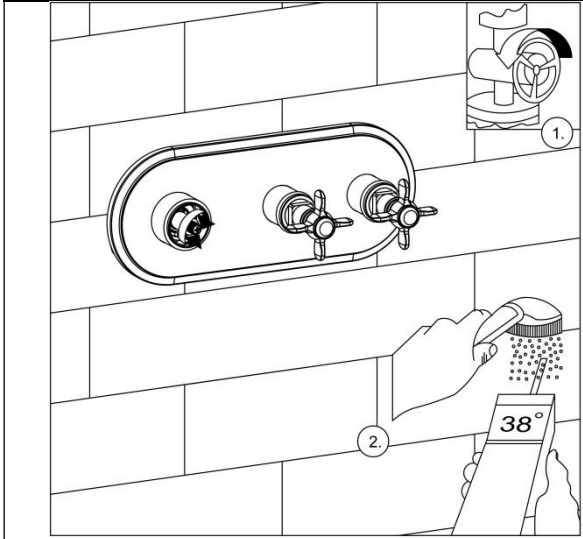

Open water supply for hot and cold pipelines. With the thermostatic mixer set at 38° , set the divertor to direct water to the hand shower and check the temperature with a thermometer which should correspond to the 38° setting.

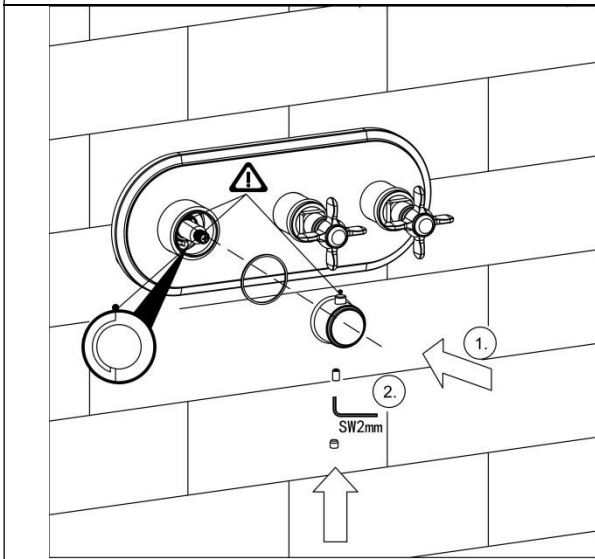

Install the thermostatic handle into position and secure it with the provided grub screw.
Clip on the decorative grub screw cap.

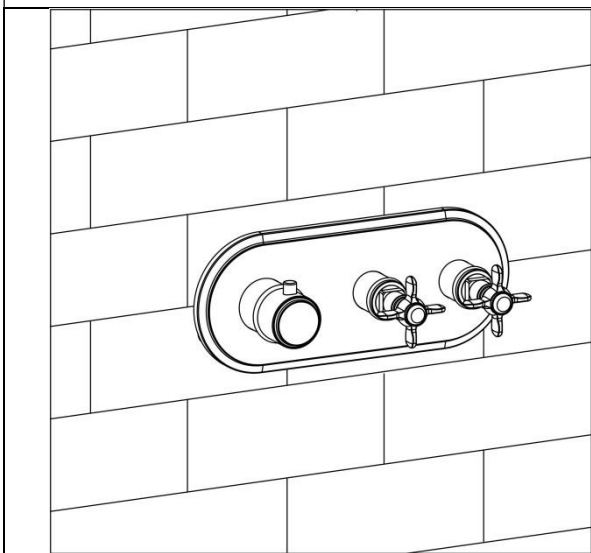

Installation is complete.

Operation

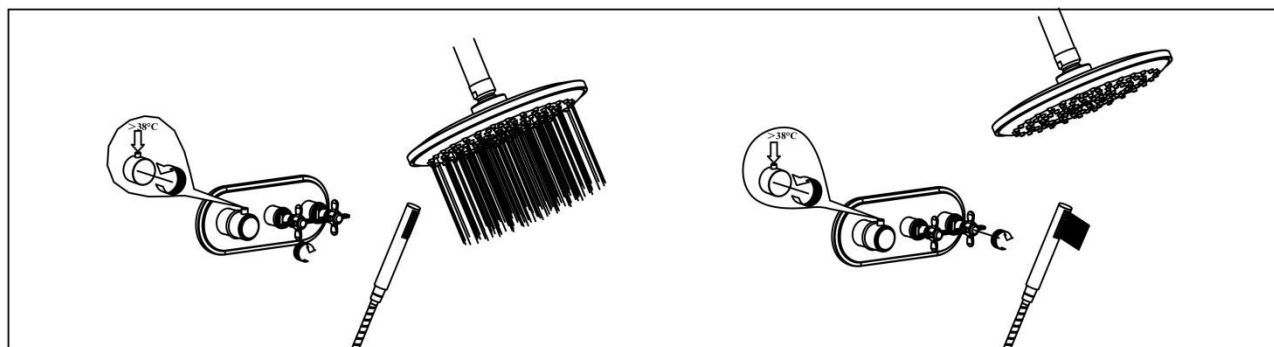

Troubleshooting

Issues	Inspection Item
Poor water flow	<ul style="list-style-type: none"> • Check if the supply pressure is inadequate • Is there dirt with the filter mesh
Crossflow, hot water being forced into cold water pipe, or vice versa, when mixer is closed	<ul style="list-style-type: none"> • Is there dirt within the check-valve(if yes, clean check-valve, exchange it if necessary)
Shower temperature does not correspond with temperature setting	<ul style="list-style-type: none"> • Has the thermostat adjusted correctly • Is the hot water temperature too low? (if yes, increase hot water temperature to 42° to 60°)
Temperature regulation not operating	<ul style="list-style-type: none"> • Is the thermo cartridge calcified (if yes, exchange a new thermo cartridge) • For new installation: is the basic body correctly installed(which should be cold right, hot left)
Safety stop button not operating	<ul style="list-style-type: none"> • Is there damage with the spring • Is the the button calcified

Maintenance

Replacement/Cleaning of Thermostatic Cartridge/Filter Mesh

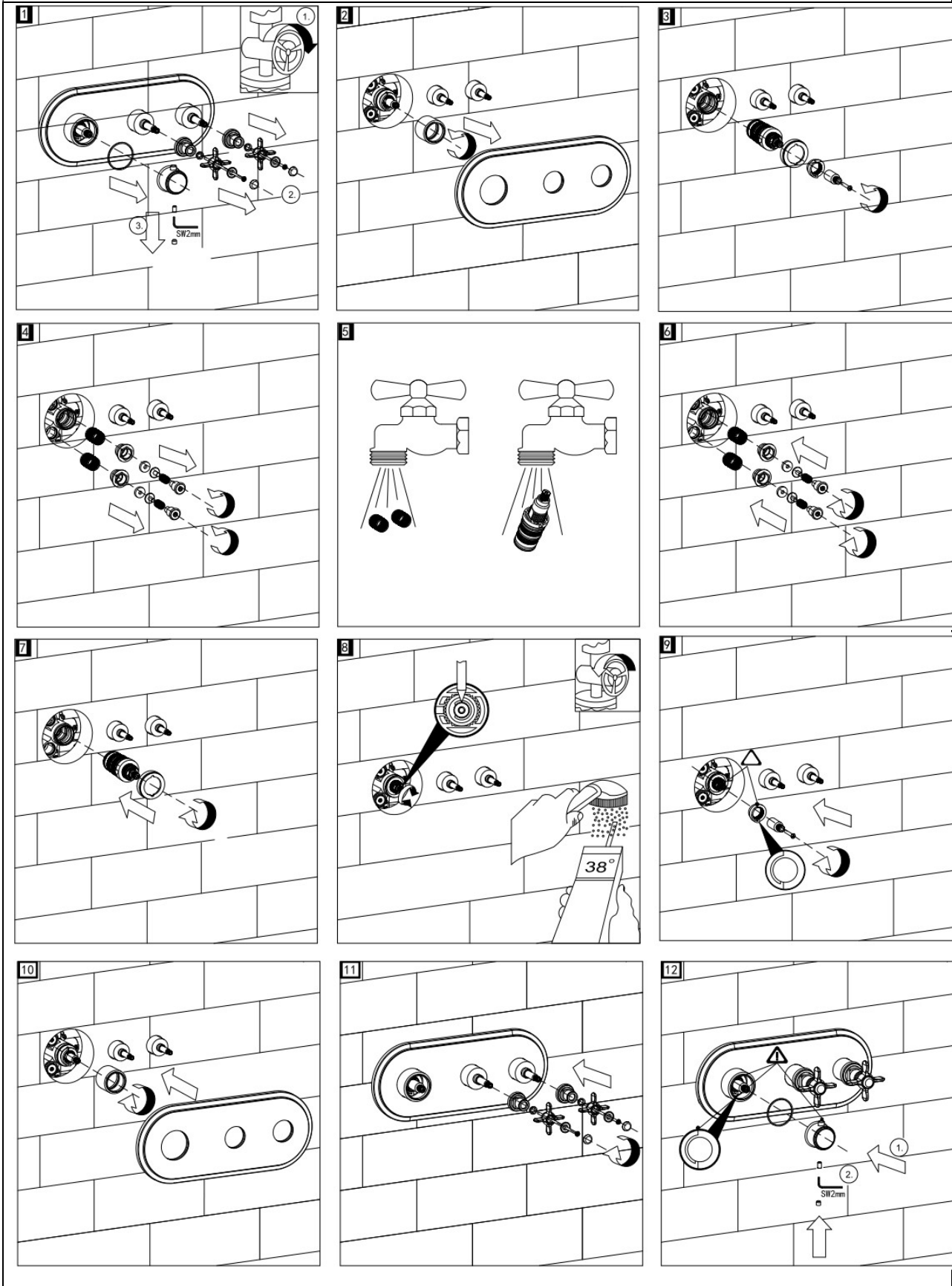

Cleaning

To maintain the surface of your product, wipe with a clean damp cloth and wipe dry, do not use any abrasive cleaning agents or materials. If any harsh chemicals come into contact with the surface of the product, rinse and wipe clean immediately.

For more information

- visit betterbathrooms.com
- email customerservices@buyitdirect.co.uk
- call 03303903062
- write to Trident Business Park, Neptune Way, Huddersfield, HD2 1UA

better 
bathrooms

Part of the BuyItDirect Group